

Isuzu Diesel Engines

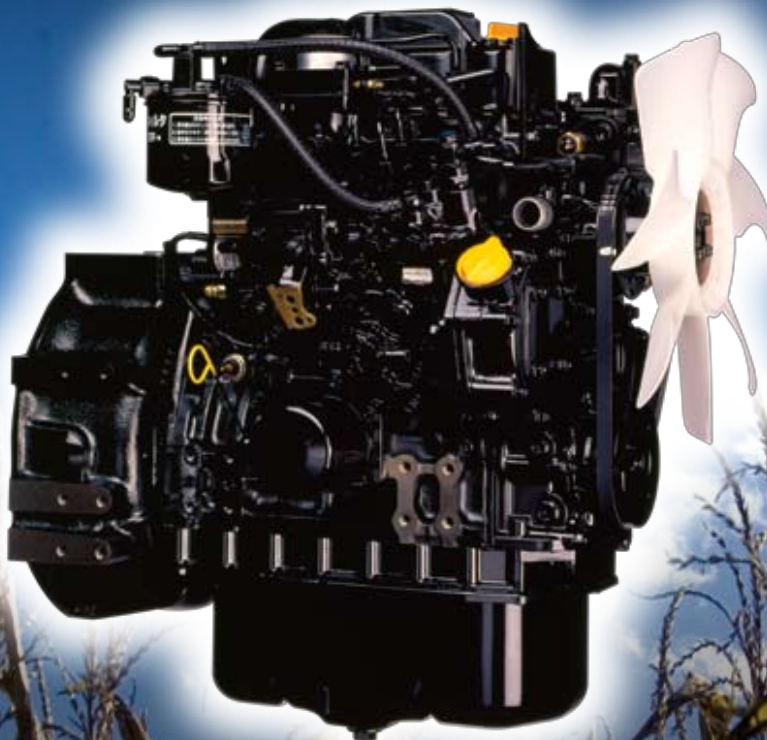

3CE1

Generator: 23.4 HP @ 1800 RPM

Industrial Drive: 38.9 HP @ 3000 RPM

Standard features:

- U.S. EPA Tier 4 Interim
- Displacement: 1.6 L
- Naturally aspirated
- Peak torque: 79.7 lb/ft @ 1200 RPM
- Fuel consumption: .395 LB/HP-HR
- Flywheel housing: SAE 5
- Electric & self-priming fuel lift pump
- 12V electrics
- Glow plug starting aid
- High angularity oil pan
- 250-hour service intervals
- 2-year / 2,000-hour warranty

The power behind it all.

ISUZU
DIESEL

3CE1 Industrial Performance Curves:

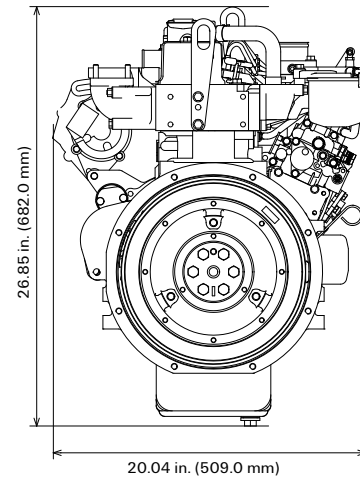
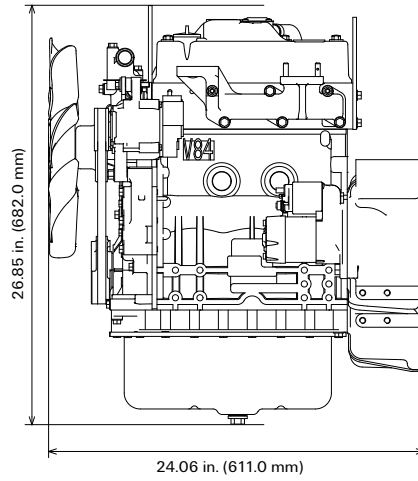
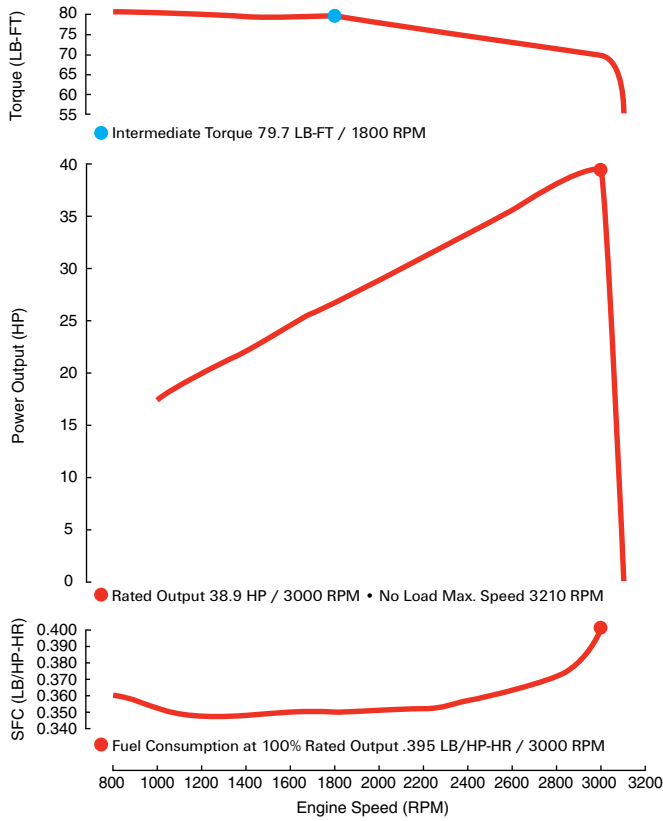

3CE1 Genset Performance Curves:

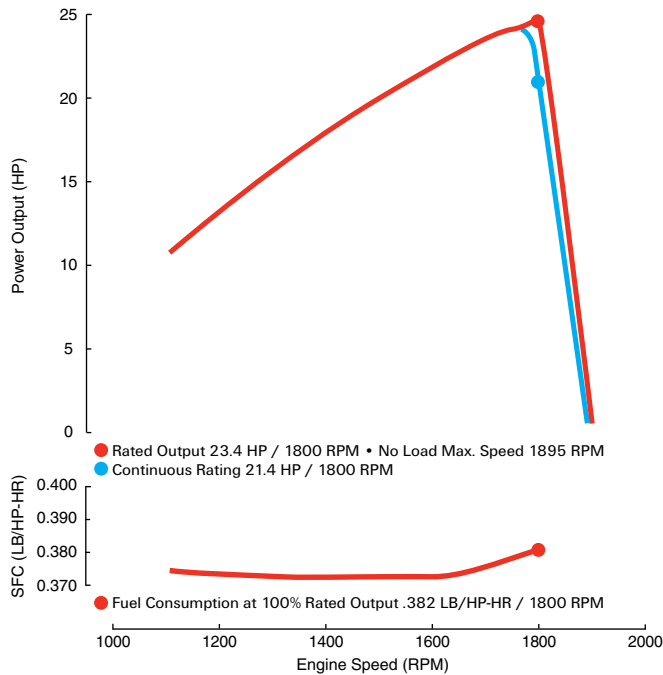

Available options:

- Cooling system
- Air cleaner
- Exhaust system
- Front and rear mounts
- Skid base
- Instrument panel & extension harness
- Custom power unit
- Electric & isochronous governor

Horsepower comparison:

Engine Model	Cylinders	Displacement (L)	HP Range
3CD1	3	1.5	20-35
3CD1T	3	1.5	30-40
3CE1	3	1.6	30-40
4LE1	4	2.2	35-50

For additional information, please contact your local distributor or visit www.isuzuengines.com

Isuzu Motors America, Inc.

46401 Commerce Center Drive
 Plymouth, Michigan 48170
 Phone: 734.582.9470
 Fax: 734.455.7581

Isuzu Diesel Engines

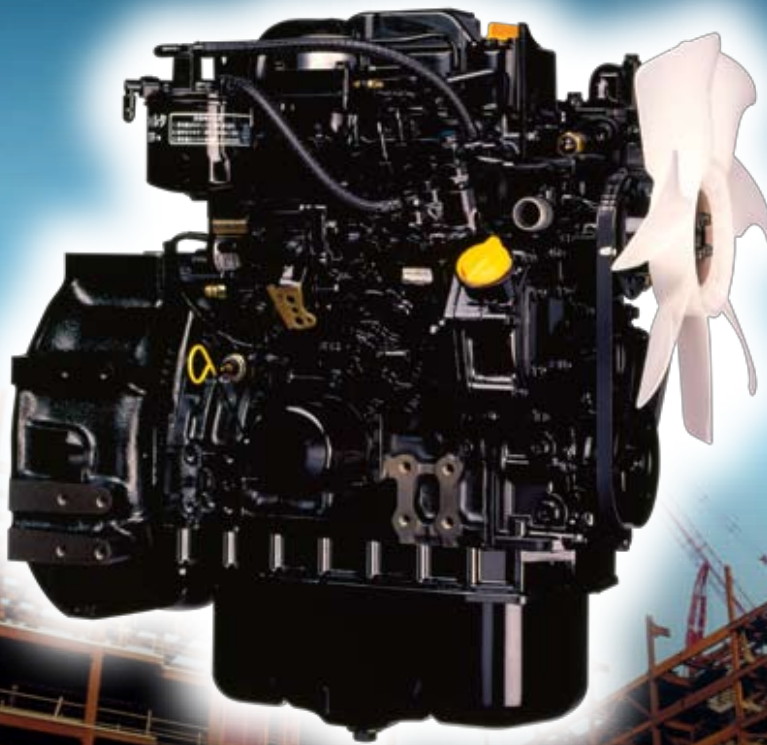

3CE1

Generator: 23.4 HP @ 1800 RPM

Industrial Drive: 38.9 HP @ 3000 RPM

Standard features:

- U.S. EPA Tier 4 Interim
- Displacement: 1.6 L
- Naturally aspirated
- Peak torque: 79.7 lb/ft @ 1200 RPM
- Fuel consumption: .395 LB/HP-HR
- Flywheel housing: SAE 5
- Electric & self-priming fuel lift pump
- 12V electrics
- Glow plug starting aid
- High angularity oil pan
- 250-hour service intervals
- 2-year / 2,000-hour warranty

The power behind it all.

ISUZU
DIESEL

3CE1 Industrial Performance Curves:

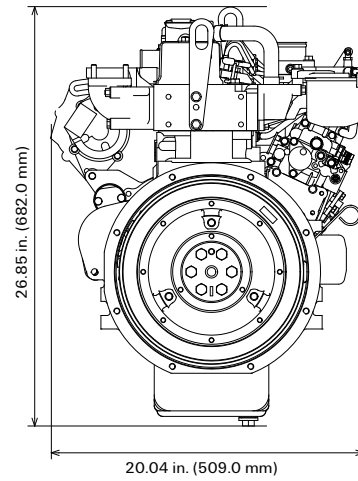
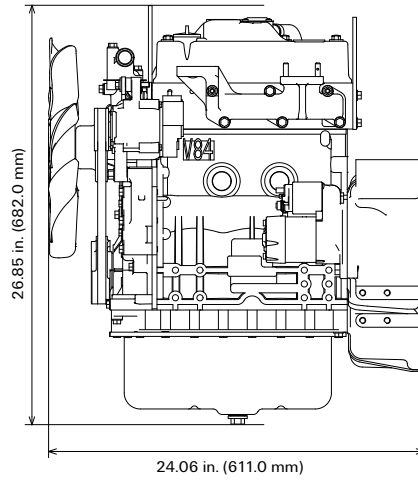
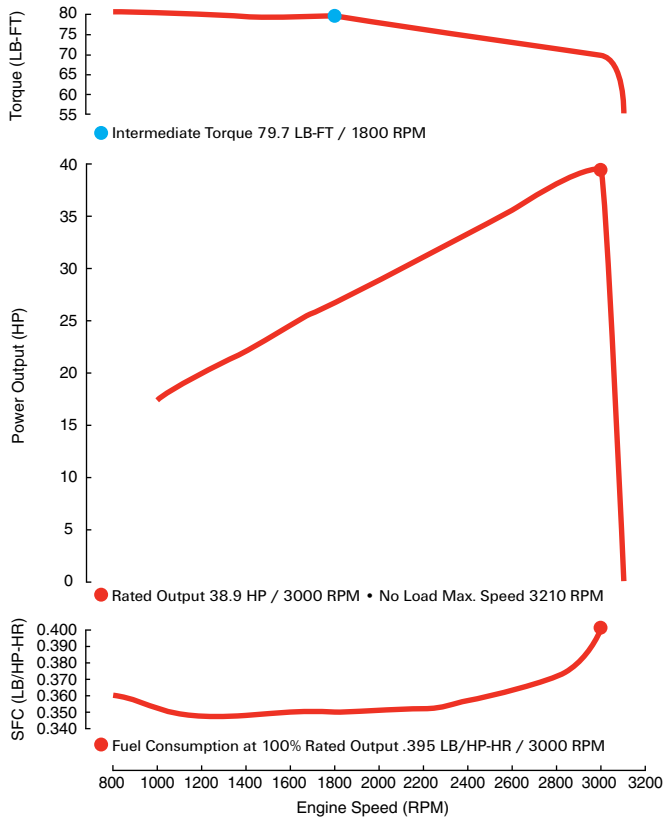

3CE1 Genset Performance Curves:

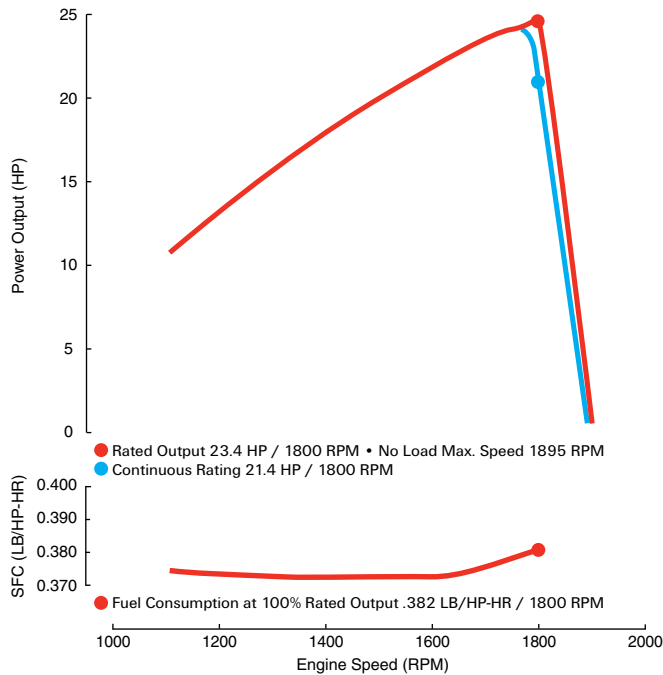

Available options:

- Cooling system
- Air cleaner
- Exhaust system
- Front and rear mounts
- Skid base
- Instrument panel & extension harness
- Custom power unit
- Electric & isochronous governor

Horsepower comparison:

Engine Model	Cylinders	Displacement (L)	HP Range
3CD1	3	1.5	20-35
3CD1T	3	1.5	30-40
3CE1	3	1.6	30-40
4LE1	4	2.2	35-50

For additional information, please contact your local distributor or visit www.isuzuengines.com

Isuzu Motors America, Inc.

46401 Commerce Center Drive
 Plymouth, Michigan 48170
 Phone: 734.582.9470
 Fax: 734.455.7581

Isuzu Diesel Engines

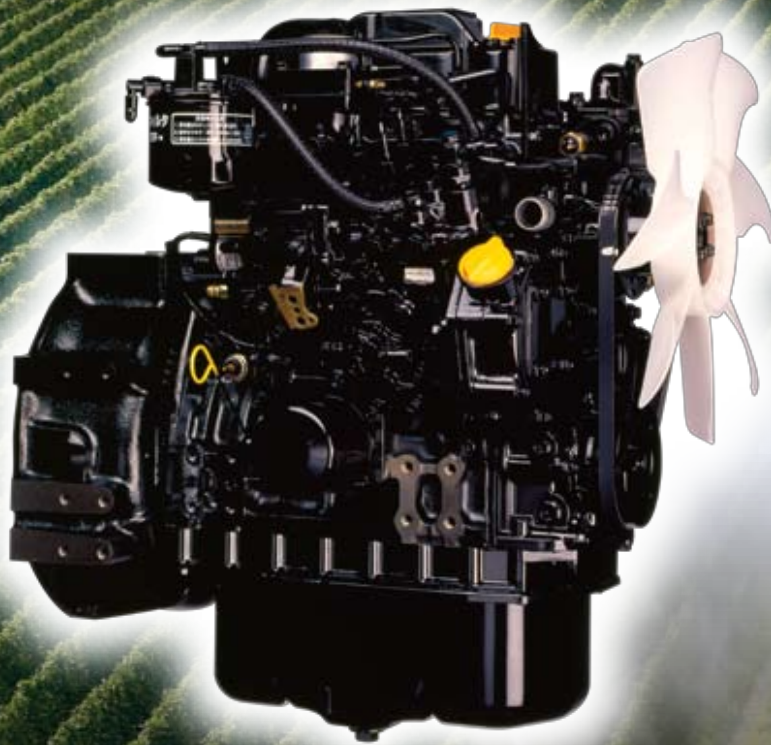

3CE1

Generator: 23.4 HP @ 1800 RPM

Industrial Drive: 38.9 HP @ 3000 RPM

Standard features:

- U.S. EPA Tier 4 Interim
- Displacement: 1.6 L
- Naturally aspirated
- Peak torque: 79.7 lb/ft @ 1200 RPM
- Fuel consumption: .395 LB/HP-HR
- Flywheel housing: SAE 5
- Electric & self-priming fuel lift pump
- 12V electrics
- Glow plug starting aid
- High angularity oil pan
- 250-hour service intervals
- 2-year / 2,000-hour warranty

The power behind it all.

ISUZU
DIESEL

3CE1 Industrial Performance Curves:

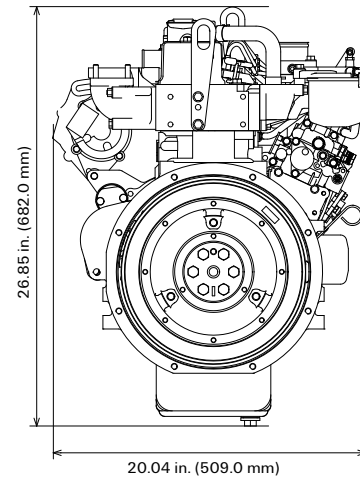
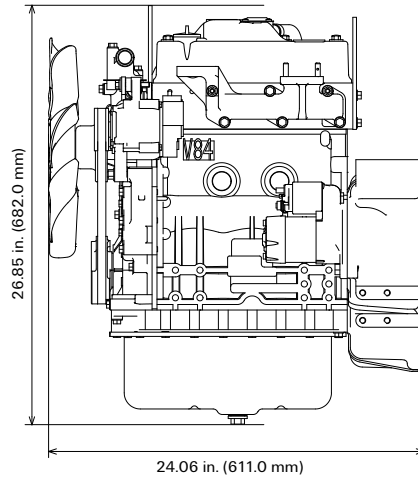
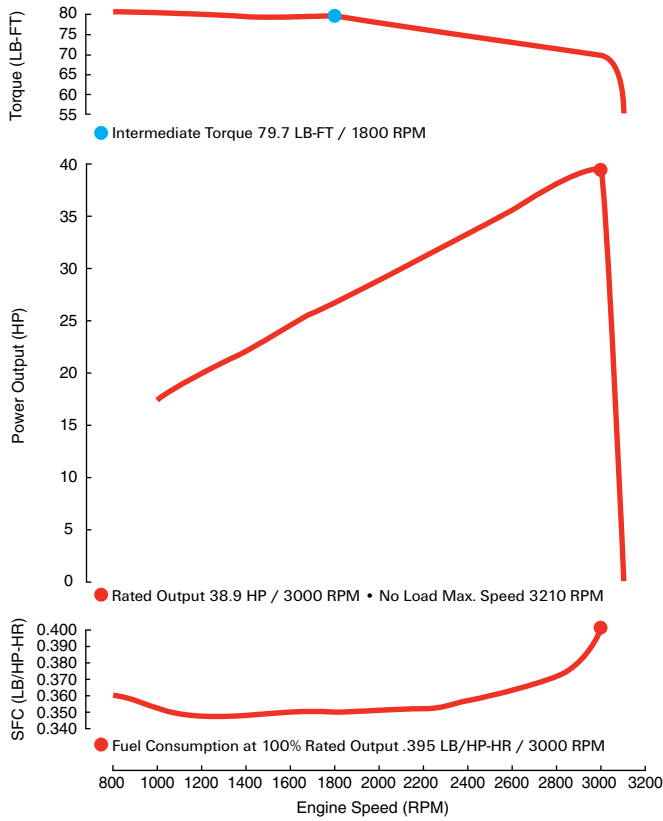

3CE1 Genset Performance Curves:

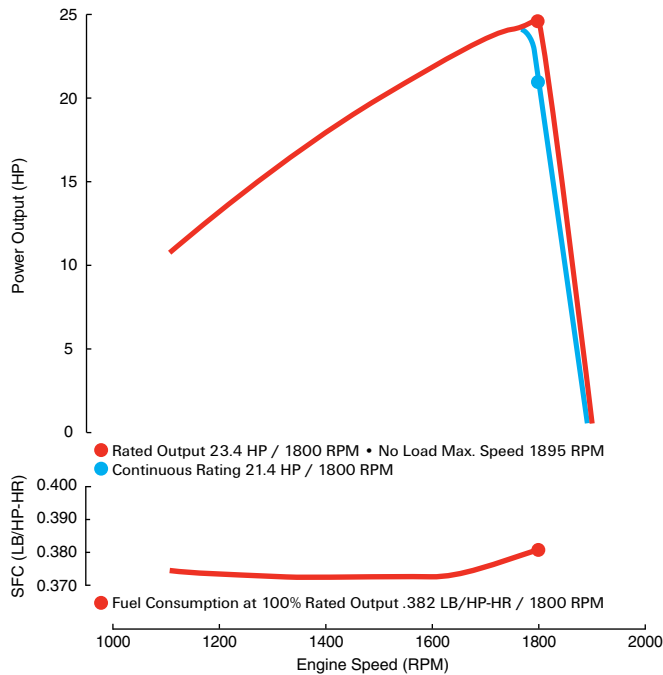

Available options:

- Cooling system
- Air cleaner
- Exhaust system
- Front and rear mounts
- Skid base
- Instrument panel & extension harness
- Custom power unit
- Electric & isochronous governor

Horsepower comparison:

Engine Model	Cylinders	Displacement (L)	HP Range
3CD1	3	1.5	20-35
3CD1T	3	1.5	30-40
3CE1	3	1.6	30-40
4LE1	4	2.2	35-50

For additional information, please contact your local distributor or visit www.isuzuengines.com

Isuzu Motors America, Inc.

46401 Commerce Center Drive
 Plymouth, Michigan 48170
 Phone: 734.582.9470
 Fax: 734.455.7581