

The performance of 3.4L engine in a 2L package

The F28 engine from FPT Industrial stands out for its compact layout and high performance in the sub-3-liter category, making it ideal for applications requiring higher productivity with a compact footprint. The after treatment system in Tier 4 Final engines is DPF free (DOC only) and is best in class for its reduced footprint.

SPECIFICATIONS

| | |
|---------------------|--|
| Type | Diesel 4 Stroke |
| Configuration | Inline 4 Cylinder |
| Air Handling | Turbocharged/Turbocharged Air Cooled (55 Kw) |
| Bore X stroke | 90.8 X 108 mm |
| Displacement | 2.8 L |
| Compression Ratio | 17:1 |
| Valves per Cylinder | 2 |
| Rotation | CCW |
| Fuel System | Electronic Common Rail |

AFTER TREATMENT SYSTEM

| | |
|---------|-----|
| Tier 4F | DOC |
|---------|-----|

PERFORMANCE RATINGS

| | |
|----------------------------|-------------------|
| 37 kW (50 HP) @ 2500 RPM* | 207 Nm @ 1400 RPM |
| 43 kW (58 HP) @ 2500 RPM* | 250 Nm @ 1400 RPM |
| 54 kW (72 HP) @ 2500 RPM* | 260 Nm @ 1800 RPM |
| 54 kW (72 HP) @ 2500 RPM** | 366 Nm @ 1400 RPM |

*TC **TCA

STANDARD CONFIGURATION

| | |
|----------------------|---------------------|
| Emissions Level | Tier 4F |
| Flywheel Housing | SAE 3 |
| Flywheel Housing | 11.5" |
| Oil Sump | Center |
| Voltage | 12V |
| Alternator | 12V - 100A |
| Starter | 12V - 3.2 kW |
| Powerpack Dimensions | 1150 x 720 x 985 mm |
| Powerpack Weight | 440 kg |

KEY FEATURES:

- Delivers performance of 3.4-liter engine in 2-liter package
- Complete pre-assembled solution for fast and easy installation
- Most compact ATS in its category for stationary and nonstationary machines
- Customizable with a set of pre-validated options
- Best-in-class 600-hour service interval minimizes downtime
- 2.8-liter displacement
- Power up to 54 kW (72 HP)
- Torque up to 366 Nm (270 lb/ft)

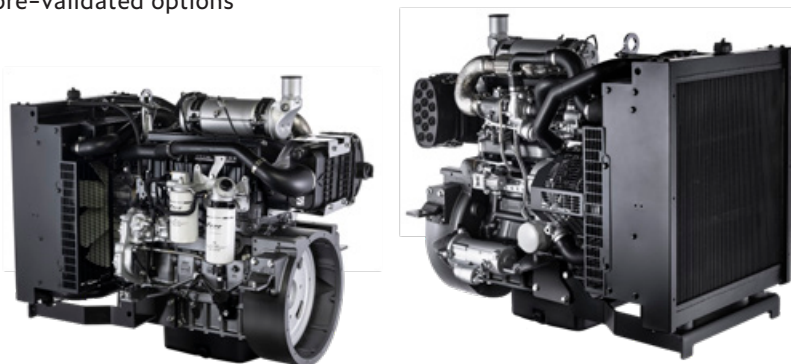

ENGINE PERFORMANCE DATA

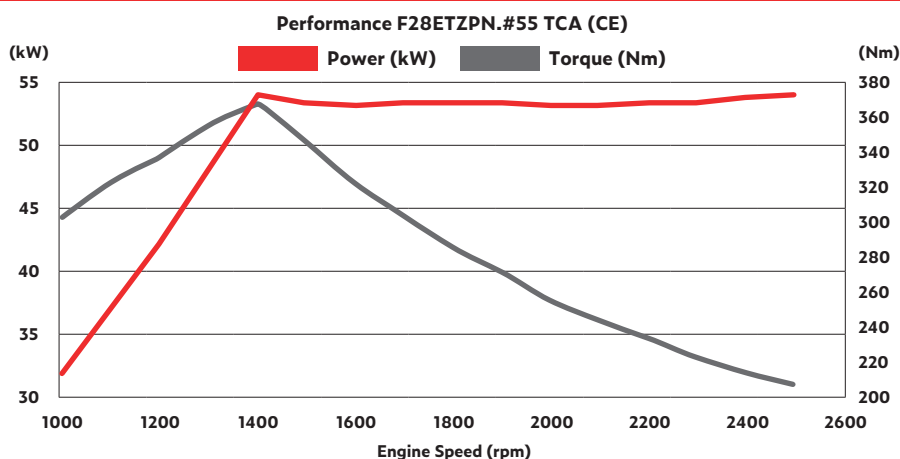

F28

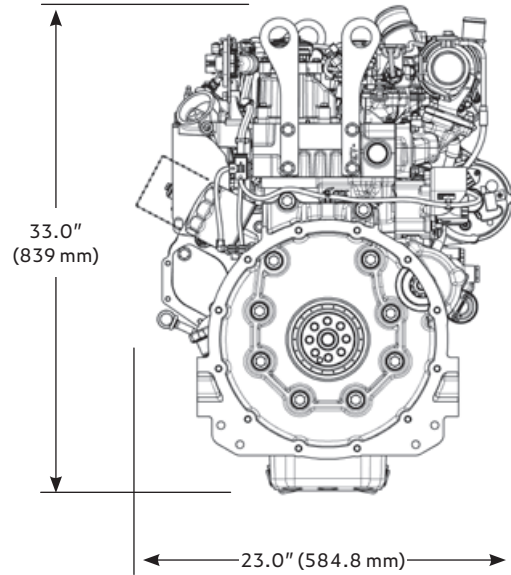
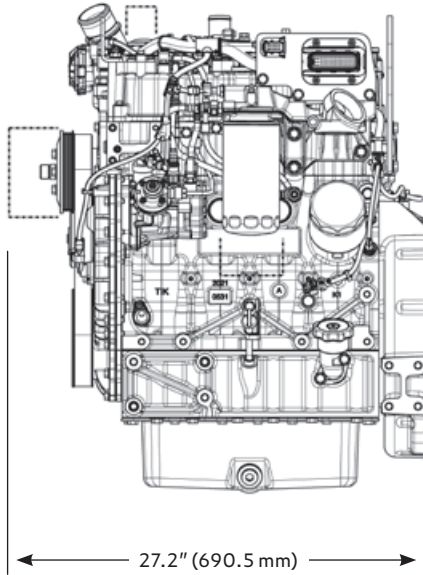

F28 POWERPACK

