



# F36ETVP03.A94

## G-DRIVE STAGE V



Brochure main description		@1500rpm	@1800rpm
<b>Application &amp; simbol</b>		Power Generation	
Engine identification main		F36	
Engine identification rating	kW	94	105
Engine features		PG G-Drive	
Emission feature		Tier4B_StageV	
Main characteristics		@1500rpm	@1800rpm
Emission certification		Tier4B_StageV	
Commercial code (for order)		F36ETVP03.A94	
Other Commercial code		F5MGL415A	
Technical code (original plant engine code, on engine block)		F5MGL415A*V001	
Technical homologation code		F5MGL415A*V	
Stand-by power (gross) [mech]	kW	94	105
Specific power	kW/l	26,2	29,2
Electric commercial power (estimation alternator power output)	kWe [kVA]	80 [100] (generator eff. 0,92)	92 [115] (generator eff. 0,92)
BMEP	bar	20,9	19,5
Oil consumption on mission (average)	% fuel consumption	0,25	
Cycle		diesel - 4 stroke	
Air charging system pattern		Turbocharged aftercooled	
Number of cylinder		4	
Configuration (cylinder arrangement)		in line	
Bore	mm	102	
Stroke	mm	110	
Stroke / Bore		1,07	
Displacement	l	3,6	
Unit Displacement	l	0,90	
Bore pitch	mm	110	
Valves per cylinder		4	
Cooling system type		liquid	
Direction of rotation (looking flywheel)		anti-clockwise	
Compression ratio		18,5 : 1	
Firing order		1 - 3 - 4 - 2	
Injection type		direct - electronic common rail	
Engine brake configuration		-	
Be10		8000 h	
<b>Cylinder Head</b>			
Single / Multiple		single	
Material		cast iron	
Head air circulation		reverse-flow	
Intake valve dia.	mm	32,5	
Exhaust valve dia.	mm	32,5	
<b>Camshaft</b>			
Layout		OHV	
Cam carrier		on cylinder block	
Material and Heat treatment		C53 bon - hardness 55 hrc on cammes	
Valve train		OHV valve train with valve pushrod and lower camshaft	



# F36ETVP03.A94

## G-DRIVE STAGE V



Main characteristics	@1500rpm	@1800rpm
Drivetrain (timing system)		gear tappet
Valve actuation		tappet & push rod
Variable valve actuation system		no
Cylinder block (crankcase)		No Structural
Material of cylinder block		cast iron
Type of liners		parent metal cylinder block
Liners replaceable; (slip fit or interference fit)		no
Bearing caps		machined cast iron
Crankcase Ventilation		closed
Oil separator		centrifugal
<b>Crankshaft &amp; counterweights</b>		
Material		GH 90-52-05 AS 15-2218
Acceptable Inertia (clutch)	kgm <sup>2</sup>	0,8
Balancing		no
<b>Turbocharger &amp; EGR system</b>		
Turbocharger type		fixed geometry with wastegate valve
Turbocharger supplier		BorgWarner
Turbocharger control		WG pneumatic control
Pressure after turbocharger compressor	mbar	2600
Max turbine inlet temperature	°C	740 cont. / 760 peak
Temperature after turbocharger compressor	°C	
Method of cooling the turbocharger		oil lubricated
Turbo protection devices		wastegate and ECU derating
EGR type		yes
EGR control strategy		external cooled EGR
EGR recirculation rate		-
Valve		Ø 21
Cooler		water cooler
Control		from engine ECU
Air mass measurement		no
<b>Exhaust flap</b>		
Exhaust flap supplier		-
Actuation type		-
Exhaust flap cooling		-
<b>Switchability (1500-1800 rpm)</b>		
Emission level 1500 rpm		StageV
Emission level 1800 rpm		Tier4B
<b>Front power take off</b>		
PTO type		-
Max torque available from front of crankshaft (no side load)	Nm	-
<b>Power take off on gear train</b>		
SAE A 9 teeth	Nm	-
SAE A 11 teeth	Nm	-
SAE B 13 teeth	Nm	-
SAE B (DIN 5482)	Nm	-
SAE 2B 15 teeth( ANSI B92,1)	Nm	-
<b>References values</b>		
Engine dimension LxWxH (indicative values)	mm	783 x 689 x 846



# F36ETVP03.A94

## G-DRIVE STAGE V



Main characteristics		@1500rpm	@1800rpm
G-Drive Dimension LxWxH (indicative values)	mm	1111x689x1050	
Max permissible engine inclination	deg	35	
Engine Weight - Dry (no fluids, value purely indicative)	kg	330	
Engine Weight - Wet (with fluids, value purely indicative)	kg	365	
G-Drive Weight - Dry (no fluids, value purely indicative)	kg	450	
G-Drive Weight - Wet (with fluids, value purely indicative)	kg	470	
Center of gravity (FFOB or RFOB according to picture, standard engine layout)	mm	x = - 8 ; y = 140 ; z = 190	
Principal moment of inertia (reference on center of gravity ,standard engine layout)	kgm <sup>2</sup>	I1 = 14 kgm <sup>2</sup> ; I2 = 23 kgm <sup>2</sup> ; I3 = 27 kgm <sup>2</sup>	
Principal moment of inertia (reference matrix based on center of gravity,standard engine layout)	kgm <sup>2</sup>		
Center of gravity (FFOB or RFOB according to picture, standard IPU/G-Drive layout)	mm	x = 6 ; y = 168; z = - 281	
Principal moment of inertia (reference on center of gravity ,standard IPU/G-Drive layout)	kgm <sup>2</sup>	I1 = 21 kgm <sup>2</sup> ; I2 = 32 kgm <sup>2</sup> ; I3 = 40	
Principal moment of inertia (reference matrix based on center of gravity,standard IPU/G-Drive layout)	kgm <sup>2</sup>		
Mass moment of inertia - rotating components (excluding flywheel)	kgm <sup>2</sup>		
Mass moment of inertia - standard flywheel	kgm <sup>2</sup>	1,189	
Bending moment on the flywheel housing	Nm		
Flywheel housing SAE sizing			
Flywheel SAE sizing			
Bending moment on PTO	Nm	-	
Max static mounting surface load	N	N/A	
Crankshaft thrust bearing pressure limit			
Intermittent load:	MPa	N/A	
Continuous load:	MPa	N/A	
Rear main bearing load	MPa	N/A	
Max bending moment available from front of the crankshaft:			
0 deg	Nm	100	
90 deg	Nm	300	
180 deg	Nm	300	
<b>Environmental operating conditions</b>			
Max altitude for declared performances	m	1000	
Max ambient temperature for declared performances	°C	40	
Min guaranteed temperature for cold start w/o any aid (stand alone engine)	°C	- 15	
Min guaranteed temperature for cold start with grid heater (stand alone engine)	°C	-	
Min guaranteed temperature for cold start with grid heater and block heater (stand alone engine)	°C	- 32	
Time preheating for manifold heater	s	-	
Time post heating for manifold heater	s	-	
Low idle continuous operation time (reccomended)	h	N/A	
<b>Engine performance</b>			
Continuous power (gross) [mech]	kW	75,2	84
Prime power (gross) [mech]	kW	94	105
Stand-by power (gross) [mech]	kW	94	105



# F36ETVP03.A94

## G-DRIVE STAGE V



Main characteristics		@1500rpm	@1800rpm
Fan consumption [mech]	kW	3,36	5,8
Continuous power (net) [mech]	kW	72,4	79,3
Prime power (net) [mech]	kW	90,6	99,2
Stand-by power (net) [mech]	kW	90,6	99,2
Typical generator output		92%	92%
Generator available power @ Prime power	kW	83,4 (generator eff. 0,92)	91,3 (generator eff. 0,92)
Generator available power @ Stand by	kW	83,4 (generator eff. 0,92)	91,3 (generator eff. 0,92)
<b>Power limitation according to ambient conditions</b>			
Ambient temperature above xx°C	%/5°C (xx°C)		2
Altitude > 1000 < 3000m above sea level	%/500m		3
Altitude > 3000m above sea level	%/500m		6
<b>Power limitation due to safety protections</b>			
Max water temperature (Switch on of the MIL lamp)	°C		104
Start derating: switch on of the warning coolant temperature lamp (amber color)	°C		106
Max derating (50% derating) switch on of the high coolant temperature lamp (redcolor)	°C		110
Altitude level: gradual reduction of transient response by smoke map correction from	m		2000
Fuel temperature	°C		70
Intake manifold air temperature	°C		70
ATS Max gas inlet temperature	°C		600
Max allowed exhaust temperature	°C		740°C (760 peak)
Turbine overheating protection	°C		N/A
Turbine overspeed protection	rpm		N/A
Oil temperature protection	°C		125
Oil pressure protection (min engine rpm)	bar		
<b>Fuel System</b>			
Fuel density	kg/l		0,84
Injection system type			electronic common rail
Injection pump manufacturer			BOSCH
Injection model type			common rail
Injection model pump			CP4N1
Injection pressure	bar		1600
Injector			CRI 2-160HW
Injector installation (sleeve, sealing flat or conical)			sealing flat
Injector nozzle			8 x 350
Engine fuel compatibility			See dedicated GOLD Book document on fluids
Feed pump on engine			integrated in high pressure pump
Max fuel flow supply line	l/h		
Nominal feed pressure	bar		1
Fuel filter			single Cartridge on left side
Fuel filter clogging sensor			no
Max continuous allowable fuel temperature (without derating)	°C		70
Max relative pressure at gear pump inlet	bar		N/A
Min relative pressure at gear pump inlet	bar		N/A
Max back flow relative pressure	bar		
Max back flow restriction	bar		
Max heat rejection to return fuel	kW		



# F36ETVP03.A94

## G-DRIVE STAGE V



### Fuel System

Max fuel flow return line	kg/h	@1500: 20,1 kg/h @1800: 22 kg/h	
Min fuel tank venting requirement	m <sup>3</sup> /h		
Prefilter / Water separator micron size	µm	>99% @30	

### Air Intake System

		@1500rpm	@1800rpm
Aftercooling system type		air to air	
Interstage cooling type		-	
RoA (Temperature raise between ambient and inlet to engine)	°C	10	
Filter air intake temperature (warm air ricirculatuion)	°C	40	
Max intake manifold temperature	°C	50	
Compressor inlet pressure (with new air filter)	hPa	> - 50	
Compressor inlet pressure (with dirty air filter)	hPa	> - 65	
Air filter type		cartridge	
Loads on turbocharger on compressor intake	kg	0	
Loads on turbocharger on compressor outlet	kg	0	
Charge air flow (max)	kg/h	382	425

### Exhaust System

		@1500rpm	@1800rpm
Max back pressure (after exhaust flap) @ rated power with clean system	hPa	220	
Max mechanical load on turbine flange	kg	0	
Max ambient temperature for exhaust flap actuator	°C	-	
Max exhaust temperature After Treatment System	°C	740 cont. / 760 peak	
Max exhaust flow rate	kg/h	401 (1500 rpm) ; 446 (1800 rpm)	
Energy to exhaust	kW	73,5	64,7

### After Treatment System

After Treatment System	DOC + DPF + SCR-T		
POC	not installed		
DPF	yes		
DOC	yes		
SCR	yes		
Urea Dosing System	yes		
AdBlue mixer	yes		
ATS sensors	DeltaP / 2x Temperature sensor Us/Ds DOC / 2x Temperature sensor Us/Ds SCRT / 2x Nox Sensor Us/Ds SCRT		
DPF regeneration strategy	active and passive		

### Lubrication System

Oil sump capacity, max level	l	8
Oil sump capacity, min level	l	6,5
Oil system capacity including filter	l	9
Oil pump type		gear pump
Oil pump drive arrangement		driven by gear
Min oil pump flow	l/min	
Max oil pump flow (@rated speed)	l/min	70
Min oil pressure @ low idle (engine oil temp at 120°C)	kPa (bar)	
Min oil pressure @ rated speed (engine oil temp at 120°C)	kPa (bar)	



# F36ETVP03.A94

## G-DRIVE STAGE V



### Lubrication System

Max oil pressure @ rated speed (engine oil temp at 120°C)	kPa (bar)	
Max oil temperature @ full load (in main gallery)	°C	125
Max oil pressure peak on cold engine	bar	
Oil cooler type		water cooler
Transducer for indicating oil temperature and pressure		signal from ECU
Max engine angularity - longitudinal / transversal (std oil pan)	deg	35
Allowed engine gradability during installation on vehicle	deg	± 4
Oil servicing intervals	h	600
Oil filter type		spin-on cartridge
Oil filter capacity	l	0,5
Max oil content admitted in blow by gas (after filter)	g/h	< 0,5
Oil for cold condition mission (T° ambient < -25°C)		see dedicated GOLD Book document on fluids

### Cooling system

	@1500rpm	@1800rpm
Type (water to water or air to water)		air to water
Recommended coolant	50% water and 50% coolant (depending on mission)	
Min radiator cap pressure	kPa	100
Warnnig setting first threshold	°C	106
Max additional restriction (cooling system)	Pa	N/A
Air to boil (prime power, open genset configuration). For further information see GB document	°C	55°C @1500rpm ; 53°C @1800rpm
Air flow (prime power, open genset configuration)	m³/s	
Air to boil (stand by, open genset configuration). For further information see GB document	°C	N/A
Air flow (stand by, open genset configuration)	m³/s	
EGR Cooler water flow (for ΔT=6°C)	l/s	N/A
LP-CAC water flow (for ΔT=6°C)	l/s	N/A

### Fan

Diameter	mm	550
Number of blades		10
Drive ratio		1,3
Speed		@1500rpm:1950rpm ; @1800rpm:2340rpm
Air flow		@1500rpm: 2,5 m3/s ; @1800rpm: 3 m3/s
Power consumption		@1500rpm:3,36kW ; @1800rpm: 5,8kW

### Radiator

Core dimensions LxWxh	mm	625 x 267,5 x 840
Dry weight	kg	44,5
Radiator coolant capacity	l	5,5
Optimum coolant temperature range @engine out (50% glycol)	°C	
Engine Water pump Type		centrifugal pump
Engine water pump drive		driven by belt
Coolant capacity (engine only)	l	5
Coolant capacity (radiator & hoses)	l	7
Thermostat type		wax type
Thermostat position		on cylinder head
Thermostat opening / fully open temperature	°C	79 ± 2 / 94 ± 2
Recommended coolant circuit pressurization range (relative)	hPa	



# F36ETVP03.A94

## G-DRIVE STAGE V



Cooling system		@1500rpm	@1800rpm
Coolant engine pressure outlet – inlet (delta pressure, open thermostat, high idle conditions)	hPa	@1500rpm:132,8 hPa ; @1800rpm:182,4	
Coolant engine pressure outlet – inlet (only with remote thermostat, ex. retarder)	hPa	-	
Min coolant pressure (no pressure cap and thermostat closed)	hPa	-	
Coolant water pump inlet pressure (water temperature 60-100°C)	hPa		
Coolant flow to radiator @rated speed	l/h	N/A	
Min coolant expansion space (% total cooling system capacity)	%	N/A	
Max coolant flow to accessories @ rated speed from cab heater	l/min	N/A	
Engine out coolant to ambient @rated speed	delta °C	61,6	
Engine out coolant to ambient @torque speed	delta °C	N/A	
Charge air cooler outlet to ambient @max rpm - CAC dT	delta °C	N/A	
Pump water flow	l/min	105	134

Electrical, Electronic and Control Systems			
System voltage	V	12	
Engine control unit		MD1CS069	
ECU software		P1738_MD1CS069_522.a2l	
ECU Vehicle connection		with CAN line	
ECU operating range	°C	- 40 ÷ + 125	
Temperature of ECU case for <5' after power up	°C	85	
ECU rated continuous temperature	°C	80	
ECU communication protocol		SAE J1939	
Min power supply for ECU operation	V	10	
Max power supply for ECU operation	V	16	
Battery wire connection resistance value @20°C (from battery to ECU)	mΩ	≤ 70	
Diagnostic connector type		ISO 14229	
Min cranking speed TDC @-30°C	rpm	70	
Average cranking speed	rpm	110	
N° tooth pinion/crown gear		10 / 126	
Min battery voltage	V		
Mean battery voltage	V		
Min battery current	Ah	TBC	
Mean battery current	Ah	101	
Max starting circuit resistance ( to starter)	mΩ	< 70	

Cold starting			
Without air preheating	°C	- 15	
With air preheating (if available)	°C	-	

Emission gaseus and particuales			
NOx (Oxides of nitrogen) [NRSC]	g/kWh	see homologation certificate	
HC (Hydrocarbons) [NRSC]	g/kWh	see homologation certificate	
NOX+HC [NRSC]	g/kWh	see homologation certificate	
CO (Carbon monoxide) [NRSC]	g/kWh	see homologation certificate	
PM (Particlutes) [NRSC]	g/kWh	see homologation certificate	
CO2 (Carbon Dioxide) [NRSC]	g/kWh	see homologation certificate	



# F36ETVP03.A94

## G-DRIVE STAGE V



### Emission gaseus and particulales

NOx (Oxides of nitrogen) [NRTC]	g/kWh	see homologation certificate
HC (Hydrocarbons) [NRTC]	g/kWh	see homologation certificate
NOX+HC [NRTC]	g/kWh	see homologation certificate
CO (Carbon monoxide) [NRTC]	g/kWh	see homologation certificate
PM (Particulates) [NRTC]	g/kWh	see homologation certificate
CO2 (Carbon Dioxide) [NRTC]	g/kWh	see homologation certificate

### Maintenance

Oil drain interval		600h
Oil filter change		600 h
Oil refilling time		daily check to evaluate oil refill necessity
Approved engine oil specifications		
CCV filter change		1800 h
Fuel filter change		600 h
Fuel pre-filter change		600 h
Belt replacement		3000 h
Valve lash check /adjustment		for life
AdBlue filter Change		see dedicated GOLD Book document on fluids
DPF filter service		600 h
Coolant change		3000 h

### Engine Noise

Overall sound pressure (engine only)	dBA	92,5
Overall sound pressure (with accessories only)	dBA	N/A
Exahust noise (w/o Muffler)	dBA	N/A
Noise spectrum (octave analysis performed at the position of maximum noise) - diagram	Table dB-Hz	N/A
A-weight sound power level LW function of power (value calculated respecting standard ISO 3744 and 3746. For further information see GB document)		
0% (no load)	dBA	
75% (partial load)	dBA	
100% (full load)	dBA	
110% (overload)	dBA	

### Step Load (for further information see GB document)

		@1500rpm	@1800rpm
G1 (% of PrP)	%	N/A	77
G2 (% of PrP)	%	61	66
G3 (% of PrP)	%	50	56
G1 (% of PrP) [open flap]	%	-	-
G2 (% of PrP)[open flap]	%	-	-
G3 (% of PrP)[open flap]	%	-	-
G1 (% of PrP) [ closed flap]	%	-	-
G2 (% of PrP) [closed flap ]	%	-	-
G3 (% of PrP) [closed flap]	%	-	-
Removal load (G1)	%	N/A	N/A
Removal load (G2)	%	N/A	N/A
Removal load (G3)	%	N/A	N/A
Emergency (xxx)	%	N/A	N/A
Emergency (xxx)	%	N/A	N/A





# F36ETVP03.A94

## G-DRIVE STAGE V



Step Load (for further information see GB document)		@1500rpm	@1800rpm
Emergency (xxx)	%	N/A	N/A
Maximum Rating Performance Data		@1500rpm	@1800rpm
Torque	Nm	609	557
Ambient Temperature	°C	25	25
EGR Rate	%	<10	<10
Fuel Flow	g/s	5,6	6,1
Fuel consumption (BSFC) (prime power)	(kg/h) [g/kWh]	[210]	[210]
Fuel consumption (BSFC) (stand by)	(kg/h) [g/kWh]	[209]	[210]
Fuel consumption (BSFC) (80% prime power)	(kg/h) [g/kWh]	[205]	[204]
Fuel consumption (BSFC) (50% prime power)	(kg/h) [g/kWh]	[206]	[209]
Fuel consumption (BSFC) (25% prime power)	(kg/h) [g/kWh]	[234]	[243]
AdBlue consumption (prime power)	% of fuel cons	4,3	4,2
AdBlue consumption (stand by)	% of fuel cons	3,5	3,6
AdBlue consumption (80% prime power)	% of fuel cons	4,5	4,7
AdBlue consumption (50% prime power)	% of fuel cons	6,1	5
AdBlue consumption (25% prime power)	% of fuel cons	4	3
Exhaust Gas Flow	kg/h	401	446
Design air handling system data			
EGR flow	kg/h	58,5	55,7
EGR pressure	kPa	287	296,7
Boost pressure (compressor outlet)	kPa	278,5	265
Pressure drop on charge air cooling system	kPa	7,4	6,3
Max temperature after HP-Compressor	°C		
Boost temperature (includes EGR effect)	°C	170	161,2
ATS back pressure	kPa	117	121,3
Exhaust Gas Temp between HP-TC	°C		
Max Exhaust Gas Temp (after TC)	°C	507,6	517,6
Max admitted back pressure after SCR	kPa		
Max admitted back pressure after TC	kPa	117	121,3
Power engine coolant without EGR & CAC (prime power)	kW [kcal/kWh]		
Power engine coolant without EGR & CAC (stand by)	kW [kcal/kWh]		
Power high Temperature EGR Cooler (engine water) (prime power)	kW [kcal/kWh]		
Power high Temperature EGR Cooler (engine water) (stand by)	kW [kcal/kWh]		
Power to coolant due to EGR LP-Circuit (prime power)	kW [kcal/kWh]		
Power to coolant due to EGR LP-Circuit (stand by)	kW [kcal/kWh]		
Total Power to coolant (prime power)	kW [kcal/kWh]	56	58,5
Total Power to coolant (stand by)	kW [kcal/kWh]	56	58,5
Total pump water flow	l/s	1,75	2,06
Radiator Coolant Flow (5% less if continuous deaerating system, coolant according to FPT norms)	l/min		
EGR Cooler water flow (for ΔT=6°C)	l/s		
LP-CAC water flow (for ΔT=6°C)	l/s		
Power in CAC (air to air) (prime power)	kW [kcal/kWh]	13,1	13,9
Power in CAC (air to air) (stand by power)	kW [kcal/kWh]	14,4	15,3
Power Radiated	kW	13	13,4



**Design air handling system data**

Charge Air Flow	g/s	104,7	116,8
-----------------	-----	-------	-------

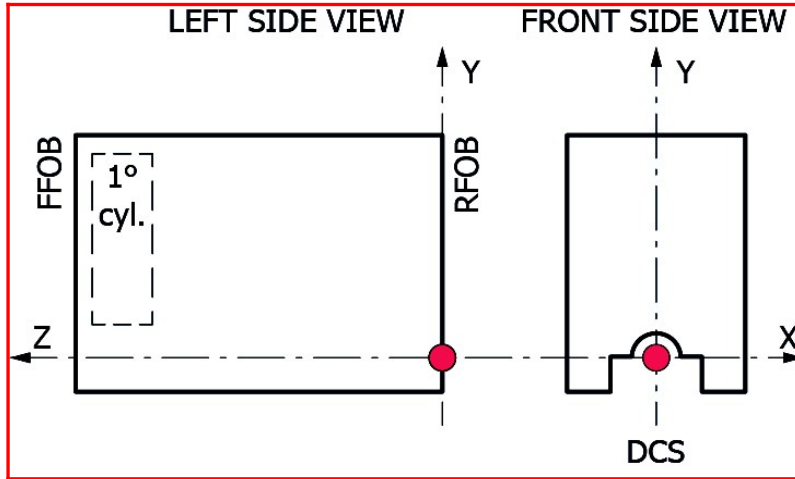

Principal Moment of Inertia

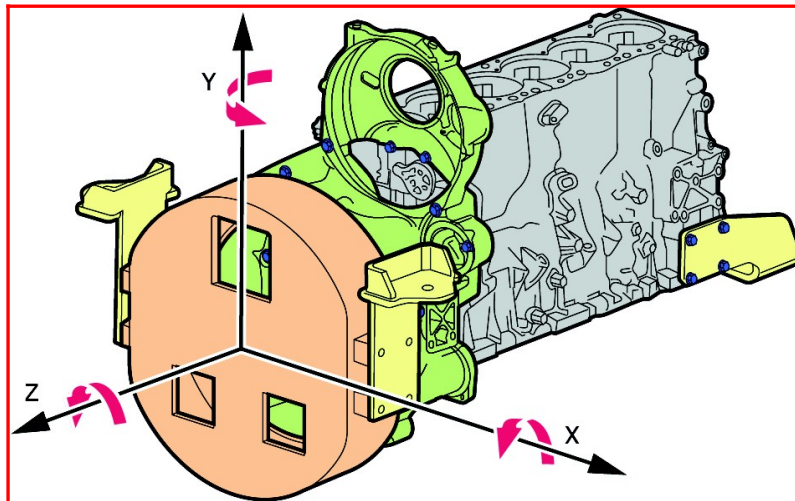

Components



**F36ETVP03.A94**  
G-DRIVE STAGE V

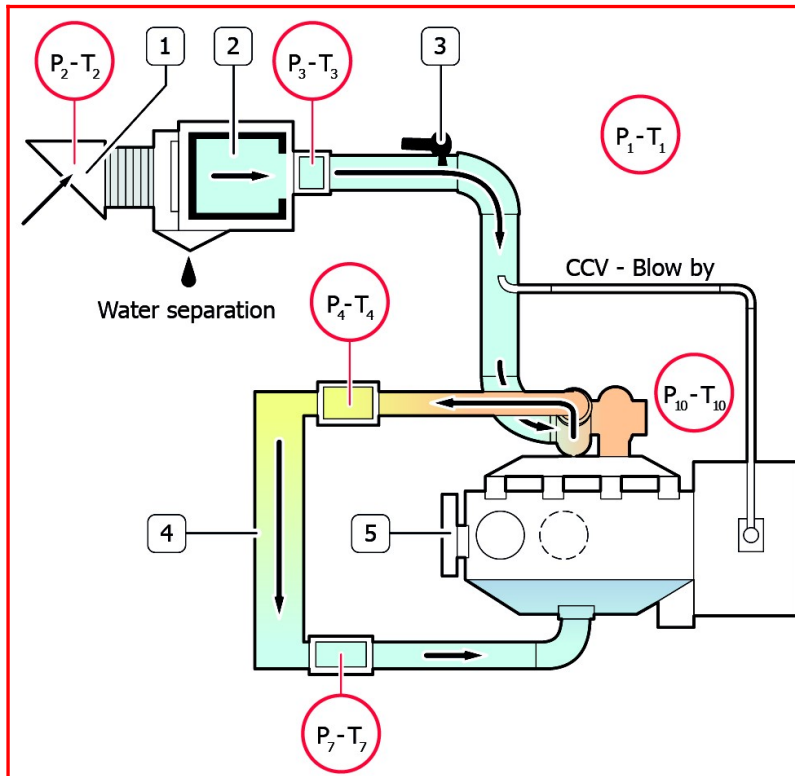

1.Snorkel 2.Air Filter 3.Humidity sensor 4.Intercooler

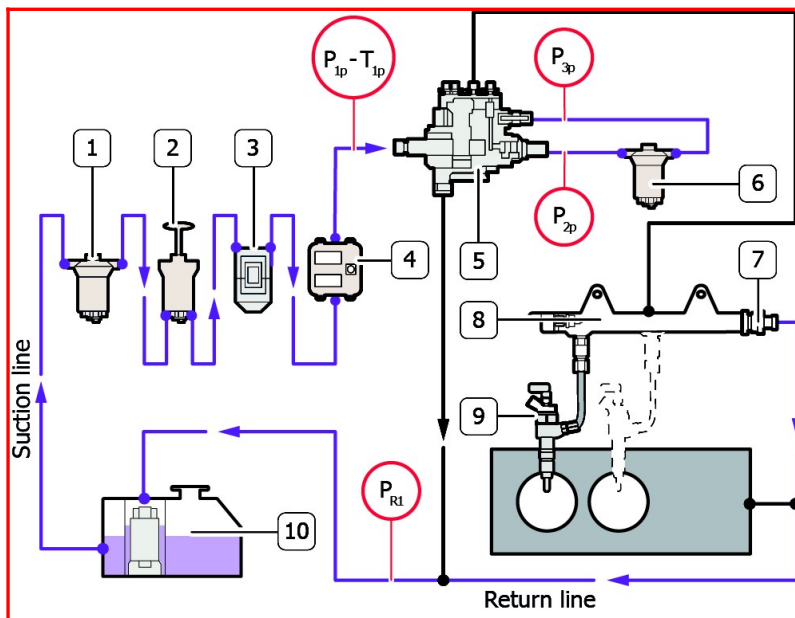

1.Inspection glass with strainer 2.Prime pump 3.Pre-filter with water separator 4.ECU 5.High Pressure pump 6.Fuel Filter 7.Overpressure valve 8.Common Rail 9.Injectors 10.Fuel tank



**F36ETVP03.A94**  
G-DRIVE STAGE V

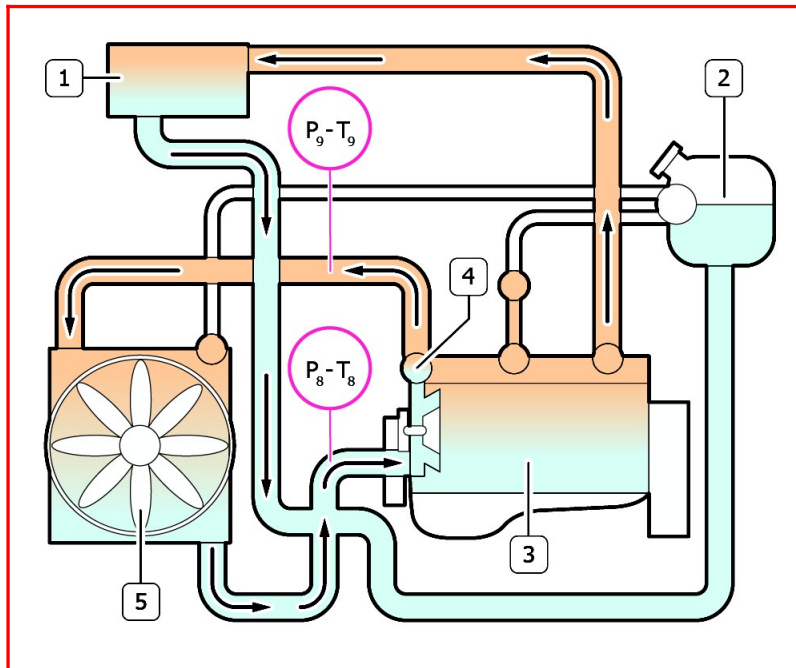

1.Heating element 2.Expansion tank 3.Engine 4.Thermostat 5.Radiator



# F36ETVP03.A94

## G-DRIVE STAGE V



### ACRONYMS LIST

Acronyms	Description
-	Not Needed
2stTC	Two Stage Turbo (sequential)
Ag	Agricultural
ASC	Ammonia Slip Catalyst (same as CUC)
ATS	After Treatment System
BSFC	Brake Specific Fuel Consumption
CAC	Charge Air Cooler
CCDPF	Close Coupled DPF
CCV	Crankcase Ventilation
CE	Construction Equipment
CI	Cast Iron
CRS	Common Rail System
CRSN	Common Rail System NKW (Commercial vehicles)
CUC	Clean Up Catalyst for ammonia (same as ASC)
DAVNT	Dual Axis Variable Nozzle Turbine
DCS	Drawing Coordinate System
DI	Direct Injection
DOC	Diesel Oxidation Catalyst
DOHC	Double Over Head Camshaft
DPF	Diesel Particulate Filter
ECEGR	External Cooled EGR
ECU	Engine Control Unit
EEGR	External EGR
EGR	Exhaust Gas Recirculation
epWG	Electro pneumatic WG
eVGT	Electrical VGT
eWG	Electrical WG
FFOB	Front Face of Block
FGT	Fixed Geometry Turbocharger (no WG)
FIE	Fuel Injection System
HD	Heavy Duty
HLA	Hydraulic Lash Adjusters
IDI	Indirect Injection

Acronyms	Description
IEGR	Internal EGR
IPU	Industrial Power Unit
ISC	Interstage Cooling
LD	Light Duty
LDCV	Light Duty Commercial Vehicles
LH	Left Hand Side
LWR	Laser Welded Rail
MD	Medium Duty
n/a	Not Available
NA	Natural Aspirated
NS	Non Structural
OHV	Over Head Valves
OPT	Option
PCP	Peak Cylinder Pressure
PTO	Power Take Off
RFOB	Rear Face of Block
RH	Right Hand Side
S	Structural
SAPS	Sulphated Ash, Phosphorus, Sulphur
SCR	Selective Catalytic Reduction catalyst
SCRoF	SCR on filter
SOHC	Single Over Head Camshaft
STD	Standard
TC	Turbocharged
TCA	Turbocharged, Charge Air Cooled
THM	Thermal Management
UFDPF	Under Floor DPF
UQS	Urea Quality Sensor
VE	Bosch Distributor Mechanical Pump
VFT	Variable Flow Turbine
VGT	Variable Geometry Turbocharger
WG	Waste Gate Turbocharger
XPI	Extra high Pressure Injection (Scania, Cummins)

*Unit of misure according to international system of unit. Engine accessories and Options available on Option List. All data is subject to change without notice.*

### UPDATING

Revision	Description	Date
Revision 1.6_Jul 2021		July/2021
Revision 2.0_May 2022		June/2022
Revision 2.1_Jul 2022		July/2022
Revision 2.2_Sep 2022		October/2022



**F36ETVP03.A94**  
G-DRIVE STAGE V



Revision 3.0_Mar 2023	March/2023
Revision 3.0_Mar 2023	March/2023